

Owner's Manual
This unit is intended for commercial use.



**8 Gallon Industrial (Commercial)
Wet/Dry Vacuum
With Certified HEPA Filtration
Model No. VK811PH**

FOR YOUR SAFETY

Read and understand this manual before use.
Keep this manual for future reference.



TABLE OF CONTENTS

SECTION	Page
Limited Warranty.....	2
Safety Instructions and Warnings.....	3
Double Insulation Instructions.....	4
Extension Cord.....	5
Unpacking and Checking Carton Contents.....	6
General Assembly Instructions.....	7
Dry Vacuuming Operation.....	8
Liquid Vacuuming Operation.....	10
Maintenance.....	11
Installing Hepa Filter And Pre-filter.....	11
Installing & Cleaning Foam Sleeve Filter.....	12
When To Change Filters.....	13
Troubleshooting.....	13
Parts - Exploded View.....	14

Thank you for purchasing this Vacmaster® HEPA vacuum cleaner. Feel confident that with Vacmaster® you are obtaining a high quality product engineered for optimal performance. This vacuum is capable of picking up dry materials as well liquids.

FOR YOUR SAFETY CAREFULLY READ AND UNDERSTAND ALL INSTRUCTIONS.

LIMITED WARRANTY

Your new Vacmaster vacuum is a high quality, precision-made product. All parts used in the manufacturing of this vacuum have passed rigid quality control standards prior to assembly. The vacuum motor is warranted for 1 year from the date of purchase as shown on your receipt / invoice. All other parts are warranted for 90 days from the date of purchase. Filters and accessories are excluded from this warranty. Failures due to misuse, neglect, abuse or normal wear and tear are not covered by this warranty. Vacmaster shall not be responsible for any incidental or consequential damages. Please safeguard the original receipt / invoice. If you experience any problems with your vacuum during the warranty period, the original receipt / invoice will act as proof of purchase. Contact Vacmaster at 866-384-8432 for any warranty inquiries. Do not return a failed unit to the place of purchase or service center. Any charges for the shipping of a Vacmaster unit under warranty are purchaser's responsibility unless Vacmaster requests such return in writing. This warranty gives you specific legal rights, and you may also have other rights, which vary from state to state. There are no warranties, express or implied, written or verbal, which extend beyond the description found in this manual.

SAFETY INSTRUCTIONS & WARNINGS

IMPORTANT SAFETY INSTRUCTIONS

READ AND UNDERSTAND ALL INSTRUCTIONS BEFORE USING THIS VACUUM

Read and understand this owner's manual and all labels on the Wet/Dry Vacuum cleaner before operating. Safety is a combination of common sense, staying alert and knowing how your vacuum works. Use this HEPA Vac only as described in this manual. To reduce the risk of personal injury or damage to your HEPA Vac, use only Vacmaster® recommended accessories.

For household or commercial use,

SAVE THIS MANUAL FOR FUTURE REFERENCE.

When using an electrical appliance, basic precautions should always be followed including the following:

WARNING: TO REDUCE THE RISK OF FIRE, ELECTRIC SHOCK OR INJURY:

- Do not run vac unattended.
- Do not vacuum, or use this HEPA Vac near flammable liquids, gases, or explosive vapors like gasoline or other fuels, lighter fluids, cleaners, oil-based paints, natural gas, hydrogen, or explosive dusts like coal dust, magnesium dust, grain dust, or gun power. Sparks inside the motor can ignite flammable vapors or dust.
- Do not vacuum anything that is burning or smoking, such as cigarettes, matches, or hot ashes.
- Keep cord away from heated surfaces.
- Do not expose to rain. Store indoors.
- Do not unplug by pulling on cord. To unplug, grasp the plug, not the cord.
- Do not use with damaged cord, plug or other parts.
- If vac is not working as it should, has been dropped, damaged, left outdoors, or dropped into water, return it to a service center.
- Do not pull or carry by cord, use cord as handle, close a door on cord, or pull cord around sharp edges or corners.
- Do not run HEPA Vac over cord.
- Do not handle plug or the HEPA Vac with wet hands.
- To reduce the risk of health hazards from vapors or dusts, do not vacuum toxic materials.
- Do not store near hazardous materials.
- Do not use this HEPA Vac with a torn filter or without the filter installed except when vacuuming liquids as described in the operation section of this manual.
- Do not allow to be used as a toy. Close attention is necessary when used by or near children.
- To reduce the risk of injury from accidental starting, unplug power cord before changing or cleaning filter.
- Do not leave Wet/Dry Vac unattended when plugged in. Unplug from outlet when not in use and before servicing.
- Turn off Wet/Dry Vac before unplugging.
- Do not put any object into ventilation openings. Do not vacuum with any ventilation openings blocked; keep free of dust, lint, hair or anything that may reduce air flow.
- Keep hair, loose clothing, fingers, and all parts of body away from openings and moving parts.
- To reduce the risk of falls, use extra care when cleaning on stairs.
- When using for HEPA EPA RRP cleanup tasks, use only certified Vacmaster HEPA filter.
- Even when used with a HEPA filter, extremely small particles may pass through the filter, always wear appropriate protective safety equipment.

WARNING: IF FILTERS ARE CONTAMINATED OR HAVE BEEN USED, THEY MUST BE DISPOSED OF PROPERLY, PRIOR TO PERFORMING WET VACUUMING OPERATIONS.

DOUBLE INSULATION INSTRUCTIONS

This HEPA Vac is double-insulated, eliminating the need for a separate grounding system. Use only identical replacements parts. Read the instructions for Servicing Double-Insulated Wet/Dry Vacs before servicing. Use this Wet/Dry Vac as described in this manual. Observe the following warnings that appear on the motor housing of your Wet/Dry Vac.

 **DOUBLE INSULATED - GROUNDING NOT REQUIRED - WHEN SERVICING USE ONLY IDENTICAL REPLACEMENT PARTS.**

WARNING: TO REDUCE THE RISK OF ELECTRIC SHOCK- DO NOT EXPOSE TO RAIN. STORE INDOORS.

WARNING: FOR YOUR OWN SAFETY, READ AND UNDERSTAND OPERATOR'S MANUAL. DO NOT RUN UNATTENDED. DO NOT PICK UP HOT ASHES, COALS, TOXIC, FLAMMABLE OR OTHER HAZARDOUS MATERIALS, DO NOT USE AROUND EXPLOSIVE LIQUIDS OR VAPORS.

WARNING: SERVICING OF DOUBLE-INSULATED WET/DRY VACUUM

WITH A DOUBLE-INSULATED WET/DRY VACUUM, TWO SYSTEMS OF INSULATION ARE PROVIDED INSTEAD OF GROUNDING. NO GROUNDING MEANS IS PROVIDED ON A DOUBLE-INSULATED APPLIANCE, NOR SHOULD A MEANS FOR GROUNDING BE ADDED. SERVICING A DOUBLE INSULATED WET/DRY VACUUM REQUIRES EXTREME CARE AND KNOWLEDGE OF THE SYSTEM, AND SHOULD BE DONE ONLY BY QUALIFIED SERVICE PERSONNEL. REPLACEMENT PARTS FOR A DOUBLE-INSULATED WET/DRY VACUUM MUST BE IDENTICAL TO THE PARTS THEY REPLACE. YOUR DOUBLE-INSULATED WET/DRY VAC IS MARKED WITH THE WORDS 'DOUBLE INSULATED' AND THE SYMBOL  (SQUARE WITHIN A SQUARE) MAY ALSO BE MARKED ON THE APPLIANCE.

- To reduce the risk of electric shock-unplug before cleaning or servicing.
- DO NOT use without filters in place.

CAUTION: TO REDUCE THE RISK OF INJURY FROM MOVING PARTS- UNPLUG BEFORE SERVICING.

EXTENSION CORDS

When using an extension cord with your Wet/Dry Vac refer to the following table to determine the required A.W.G. wire size. Before using the cleaner make sure the power cord and extension cord are in good working conditions. Make repairs or replacements before using the vacuum cleaner. Only use extension cords that are rated for outdoor use.

Length of Extension Cord				
	25 Feet	50 Feet	100 Feet	150 Feet
110V-120V	7.5 Meter	15.25 Meters	30.5 Meters	45.7 Meters
Amps	A.W.G Wire Size			
0-6	18	16	16	14
7-10	18	16	14	12
11-12	16	16	14	12
13-16	14	12	Not recommended	

UNPACKING AND CHECKING CARTON CONTENTS

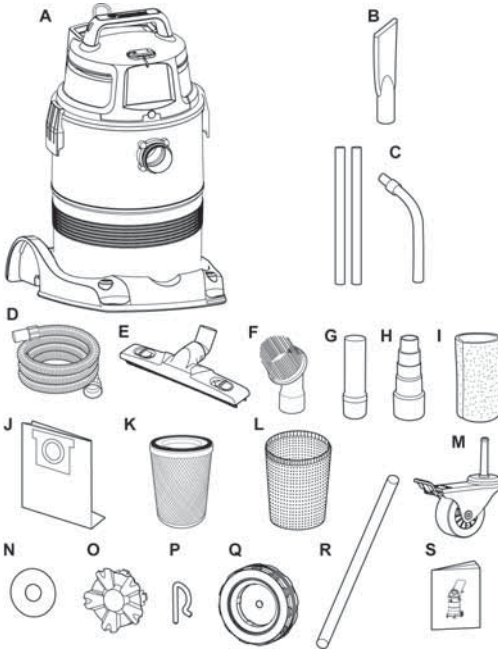

Remove entire contents of carton. Check each item against the carton contents list.

Carton contents lists

Key	Description.....	QTY.
A	Vac Assembly.....	1
B	Crevice Nozzle.....	1
C	Extension Wands.....	3
D	Hose.....	1
E	Floor Squeegee.....	1
F	Horse Hair Round Brush.....	1
G	Accessory Adaptor.....	1
H	Adaptor For Power Tools.....	1
I	Foam Sleeve.....	1
J	Dust Collection Bag.....	1
K	HEPA Cartridge Filter.....	1
L	Pre-Filter.....	1
M	Front Caster.....	2
N	Washer.....	4
O	Hub Cap.....	2
P	'R' (Lock Pin).....	2
Q	Rear Wheel.....	2
R	Wheel Axle.....	1
S	Operator's Manual.....	1

NOTE: The hose and accessories for these vacuums are 1.5 inch (38 mm) diameter.

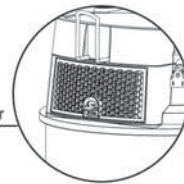
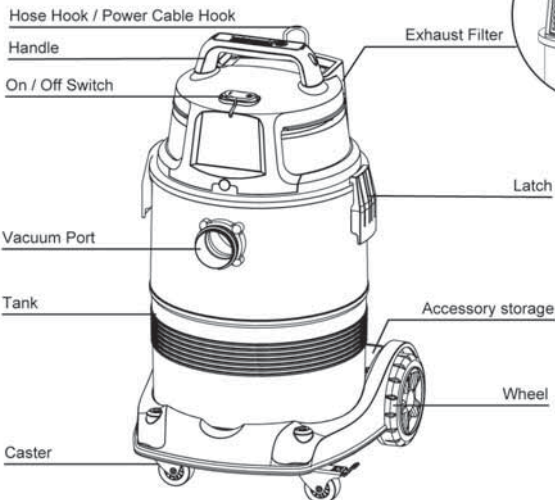

GENERAL ASSEMBLY INSTRUCTIONS

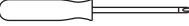
A Philips head screw driver is required. 

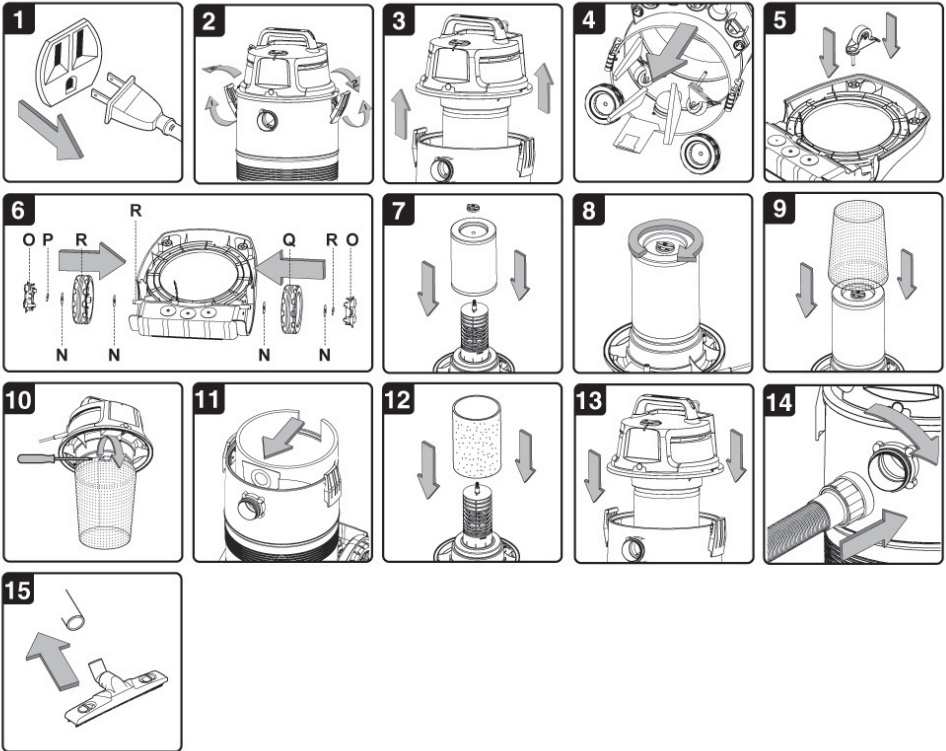

WARNING: DO NOT PLUG IN POWER CORD TO POWER OUTLET, MAKE SURE PLUG IS DISCONNECTED BEFORE ASSEMBLING THE WET/DRY VAC.

The hepa vacuum is supplied with a certified hepa filter that Has been lot tested by independent lab to IEST-RP-CC001 that meet the epa definition of a hepa vacuum (100% leak tested to 99.97% @ 0.3 micron Efficiency). It can be used for lead renovation work under the epa's lead Ppr rule. It can be used to pick up materials like sawdust and gravel, as Well as the ultra fine materials like drywall dust and cold fireplace ash.

CAUTION: This vacuum has been specifically designed to clean up hazardous dust. Special filters reduce the incidence of airborne dust that would be created by other methods of cleaning. During the removal of hazardous dust, DO NOT sweep, scoop, shovel or in any manner handle other than by vacuuming. DO NOT at any time attempt to remove, substitute or by any other means change the filters in the vacuum. Use only manufacturer's approved vacuum filters and filters bags. Before attempting to use or before cleaning with this vacuum, be sure that you fully understand the instructions for setting up or cleaning/changing filters. Any health hazards associated with use of this vacuum in conjunction with the removal of hazardous material has not been investigated by Underwriters Laboratories, Inc.

UNPACKING YOUR WET/DRY VACUUM & GENERAL ASSEMBL

1. Verify that the power cord is disconnected from the outlet. (fig. 1)
2. Undo the latches. (fig. 2)
3. Lift the power head off the tank. (fig. 3)
4. Remove the contents from inside the tank, make sure you have all contents as listed on page 6. (fig. 4)
5. Turn the tank upside down and insert the two caster feet into the front slots on the base. Apply downward pressure to each caster. Casters will "snap" into place when installed properly. Verify that the casters are mounted correctly. (fig. 5)
6. Insert the wheel axle into the base. Insert washer onto the axle followed by rear wheel and insert washer again. Insert the 'R' locking pin into the hole on the end of the axle to lock the wheel. Snap the hub cap on to the wheel. Repeat the same steps at the other end of the axle. (fig. 6)
7. Your vacuum comes ready for dry vacuum cleaning. If HEPA filter and pre-filter are not installed refer to page 11 for filter installation.(fig. 7 & 8)
8. Fit collection bag flange onto the inlet stub, taking care not to damage the bag. (fig. 11)
9. For wet vacuum cleaning, remove the pre-filter, HEPA filter and collection bag, install the supplied foam filter. (fig. 12) See page 12 for filter installation.
10. Place the power head back on the tank, aligning the top section with the latches, and hook the latches. (fig. 13)
11. Insert the locking end of the hose into the vacuum port and turn to lock in to place. (fig. 14)
12. Choose the desired accessories and push onto the suction tube. (fig. 15)

WARNING: IF FILTERS ARE CONTAMINATED OR HAVE BEEN USED, THEY MUST BE DISPOSED OF PROPERLY, PRIOR TO PERFORMING WET VACUUMING OPERATIONS.

LIGHTED PLUG

This vacuum comes standard with a lighted plug that when plugged in lights up showing user that wall receptacle is working and that vacuum has power.

DRY-VACUUM OPERATION

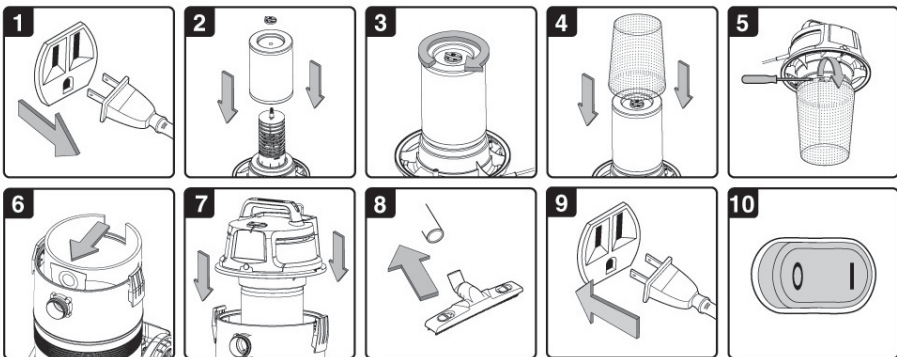

DRY VACUUM

WARNING: BE SURE TO READ, UNDERSTAND, AND APPLY INFORMATION, ENTITLED 'SAFETY INSTRUCTIONS & WARNINGS'. DO NOT VACUUM IN AREAS WITH FLAMMABLE GASES, VAPORS, OR EXPLOSIVE DUSTS IN THE AIR. FLAMMABLE GASES OR VAPORS INCLUDE BUT ARE NOT LIMITED TO; LIGHTER FLUID, SOLVENT TYPE CLEANERS, OIL-BASE PAINTS, GASOLINE, ALCOHOL OR AEROSOL SPRAYS. EXPLOSIVE DUSTS INCLUDE BUT ARE NOT LIMITED TO; COAL, MAGNESIUM, GRAIN OR GUN POWDER. TO REDUCE THE RISK OF HEALTH HAZARDS FROM VAPORS OR DUST, DO NOT VACUUM TOXIC MATERIALS.

CAUTION: NEVER operate the vacuum cleaner without all of the filters installed. This includes the HEPA filter, pre-filter and collection bag. Motor damage, lose of operating efficiency and recirculation of hazardous material into the work area will take place if not installed.

1. Verify that the power cord is disconnected from the outlet. (fig. 1)
2. In order to prepare your vacuum for dry vacuuming, verify that the HEPA filter is securely mounted. With power head removed and in upside down position, make sure the filter is pushed in until it stops against the power head and the rubber flat washer and retainer are installed. (fig. 2 & 3)
3. Slide the pre-filter onto the assembled HEPA filter. Tighten the band clamp on the pre-filter with a screwdriver to ensure. (fig. 4 & 5) (Your Wet/Dry Vac comes with the HEPA filter and pre-filter pre-installed, if not, see page 11 for installation instructions.)
4. Optional, for improved dust collecting, fit collection bag flange onto the inlet stub, taking care not to damage the bag. (fig. 6)
5. Place the power head back on the container, and secure it in place using the latches. (fig. 7)

OPERATING INSTRUCTIONS: DRY VACUUMING

1. Insert the locking end of the hose into the vacuum port and lock in place. Push the required attachment onto the free end of the hose or extension. (fig. 8)
2. Plug in the power cord into the outlet. (fig. 9)
3. Turn the motor on by flipping the switch to the 'I' ON position. (fig. 10)
4. Once you have completed vacuuming, flip the switch to the 'O' OFF position and unplug the power cord from the outlet.

O = OFF I = ON

WARNING: IF FILTERS ARE CONTAMINATED OR HAVE BEEN USED, THEY MUST BE DISPOSED OF PROPERLY, PRIOR TO PERFORMING WET VACUUMING OPERATIONS.

DO NOT USE THE HEPA FILTER FOR LIQUID VACUUMING.

Hazardous materials must be disposed of properly. NEVER throw contaminated debris in your usual trash receptacle. Place debris in a OSHA approved poly bag or container marked with HAZARDOUS MATERIAL warning and dispose in accordance with your local Hazardous Waste Regulations.

LIQUID VACUUM OPERATION

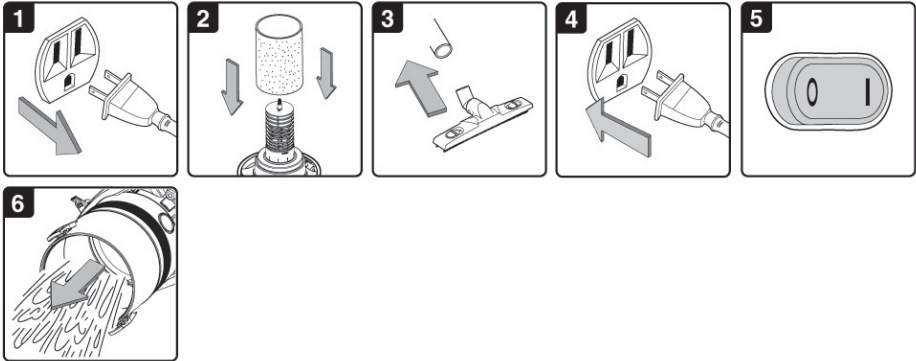

LIQUID VACUUMING

WARNING: BE SURE TO READ, UNDERSTAND, AND APPLY INFORMATION, ENTITLED 'SAFETY INSTRUCTIONS & WARNINGS'. DO NOT VACUUM IN AREAS WITH FLAMMABLE GASES, VAPORS, OR EXPLOSIVE DUSTS IN THE AIR. FLAMMABLE GASES OR VAPORS INCLUDE BUT ARE NOT LIMITED TO; LIGHTER FLUID, SOLVENT TYPE CLEANERS, OIL-BASE PAINTS, GASOLINE, ALCOHOL OR AEROSOL SPRAYS. EXPLOSIVE DUSTS INCLUDE BUT ARE NOT LIMITED TO; COAL, MAGNESIUM, GRAIN OR GUN POWDER. TO REDUCE THE RISK OF HEALTH HAZARDS FROM VAPORS OR DUST, DO NOT VACUUM TOXIC MATERIALS.

WARNING: DO NOT PLUG IN POWER CORD TO POWER OUTLET, MAKE SURE PLUG IS DISCONNECTED BEFORE ASSEMBLING THE WET/DRY VAC

1. Verify that the power cord is disconnected from the outlet. Verify that the tank is clean and free of dust and dirt. (fig. 1)
2. Remove all filters and dispose of properly.
3. Rinse out the inside of tank to remove any loose debris and dispose of liquid in suitable container.
4. Then carefully install the foam sleeve filter over the filter cage and place the power head back on the tank. (fig. 2) See filter installing instructions on page 12.

DO NOT USE THE HEPA FILTER FOR LIQUID VACUUMING.

WARNING: IF FILTERS ARE CONTAMINATED OR HAVE BEEN USED, THEY MUST BE DISPOSED OF PROPERLY, PRIOR TO PERFORMING WET VACUUMING OPERATIONS.

OPERATING INSTRUCTIONS – WET VACUUMING

1. Fit the desired nozzle to the vacuum hose. (fig. 3)
2. Verify that the switch is in the 'O' OFF position before plugging the power cord into the outlet. (fig. 4)
3. Turn the motor on by turning the switch to the 'I' ON position. (fig. 5)
4. After use, empty the tank by unscrewing the drain cap. Drain liquids into a suitable receptacle or drain. Remember to refit the drain cap to the tank after draining tank. (fig. 6)

IMPORTANT! When vacuuming large quantities of liquids, do not immerse the nozzle completely in the liquid; leave a gap at the tip of the nozzle opening to allow air inflow. The machine

is fitted with a float valve that stops the suction action when the container reaches its maximum capacity. You will notice an increase in motor speed. When this happens, turn off the machine, disconnect from power supply, and drain the liquid into a suitable receptacle or drain. To continue vacuuming, refit the container with the drain cap. After wet vacuuming, turn the machine off and remove plug from power supply. Empty the container, clean and dry the inside and outside before storage.

REMEMBER! The foam filter must be removed after wet vacuuming, and the HEPA filter must be reinstalled before dry vacuuming again.

MAINTENANCE

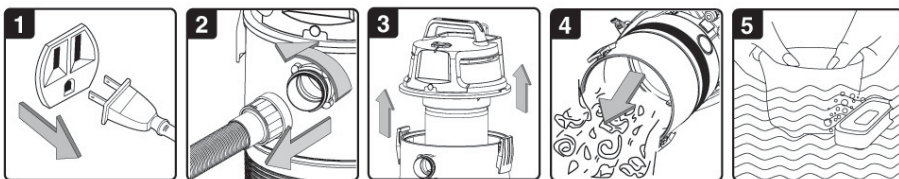

WARNING: ALWAYS DISCONNECT THE PLUG FROM THE POWER OUTLET BEFORE REMOVING THE POWER HEAD FROM THE CONTAINER.

1. Verify that the power cord is disconnected from the outlet. (fig. 1)
2. Disconnect the hose from the vacuum. (fig. 2)
3. Undo the latches and remove the power head from the container. (fig. 3)
4. Clear all dirt or debris from the container and hose. (fig. 4)
5. Clean the foam filter by washing it with water and mild soap. (fig. 5)
6. Check the hose, attachments, and power cord to verify that they have not been damaged.

INSTALLING HEPA FILTER AND PRE-FILTER

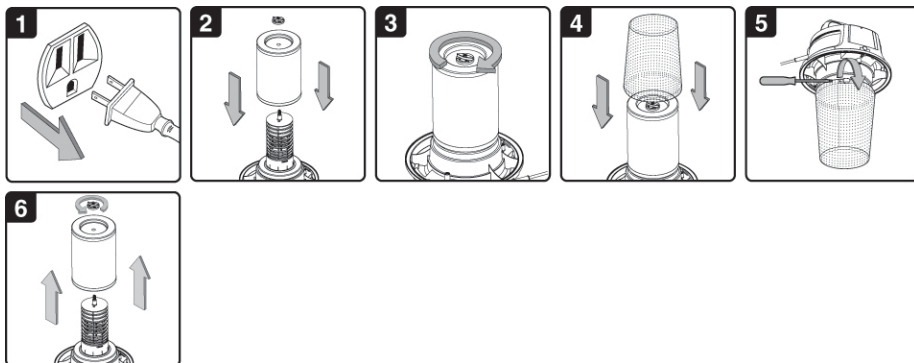

Installing HEPA Filter and Pre-Filter

1. Verify that the power cord is disconnected from the outlet. (fig. 1)
2. Remove power head and place in upside down position.
3. Install the HEPA filter over the filter cage with the flat end of the filter towards the vacuum power head. Carefully push filter in until it stops against the power head. (fig. 2)
4. Place filter retainer on top of cartridge filter over the lip and tighten down by turning retainer Clockwise, do not over tighten. (fig. 3)
5. Slide the pre-filter onto the assembled HEPA filter, over the lower end cap. Tighten the band clamp on the pre-filter with a screwdriver to ensure proper installation. (fig. 4 & 5)

Removing HEPA Filter and Pre-Filter

1. Loosen the band clamp on the pre-filter with a screwdriver, and remove the pre-filter from the HEPA filter.
2. Unlock and remove the filter retainer by tuning retainer counter clockwise.
3. Carefully hold and pull the HEPA filter up for removal. (fig. 6)
4. Install the HEPA filter into place as instructed above in steps 2 and 3 of Installing HEPA filter.
6. Wet filter should be removed and allowed to air dry for 24 hours before installing onto the filter cage.

IMPORTANT! Change the cartridge filter regularly for best performance. ALWAYS USE THE HEPA FILTER FOR DRY VACUUMING. If the machine is used for dry vacuuming without the HEPA filter and retainer attached, the motor will burn out and the warranty will be voided.

NOTICE! The HEPA cartridge filter included is made of high quality materials designed to stop small dust particles. The HEPA cartridge filter should be used for dry pick-up only. A dry HEPA cartridge filter is necessary to pick up dust. If the HEPA cartridge filter is wet, it will clog quickly and be very difficult to clean. Handle the HEPA cartridge filter carefully when removing it for replacing it. Check the HEPA cartridge filter for tears or small holes, a small hole can let dust pass through and out of the cleaner. Do not use a HEPA cartridge filter with holes or tears, replace it immediately.

INSTALLING & CLEANING FOAM SLEEVE FILTER

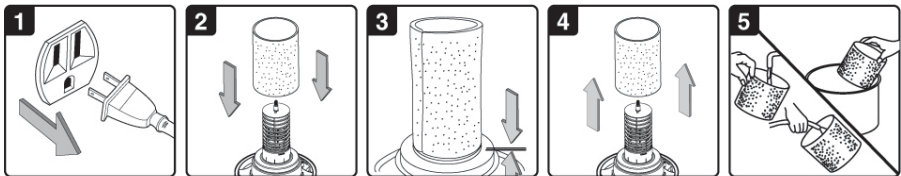

Installing Foam Sleeve Filter

1. Verify that the power cord is disconnected from the outlet. (fig. 1)
2. Remove power head and place in upside down position. Follow instructions to remove cloth filter.
3. Carefully slide foam sleeve filter down over the filter cage making sure the whole cage is covered. (fig. 2 & 3)
4. Replace the power head on to the container.

Cleaning Foam Sleeve Filter

1. With the removed power head in the upside down position, carefully remove foam sleeve filter. (fig. 4)
2. Use a mild soap and water solution to wash foam sleeve filter and rinse with clean water. (fig. 5)
3. Allow filter to air dry before installing and using again.

WHEN TO CHANGE FILTERS

Change the collection bag

When the collection bag is 3/4 full, it MUST be replaced. Excessive over filling of this bag makes it difficult to remove from the vacuum tank and can result in breakage and spills. The collection bag comes equipped with a quick closing flap. When collection bag becomes 3/4 full, turn off vacuum and slowly remove the collection bag from the tank until the opening in the collection bag is clear of the tank. Pull the closure slide up on the collection bag, which will close the opening. Hazardous materials must be disposed of properly. NEVER throw contaminated debris in your usual trash receptacle. Place closed collection bag in an OSHA approved poly bag or container marked with HAZARDOUS MATERIAL warning and dispose in accordance with your local Hazardous Waste Regulations.

Change the pre-filter

The pre-filter should be replaced with every fifth change of collection bag and whenever there is damage or a visible collection of debris on the outside of the filter.

Change the HEPA filter

Replace the HEPA filter when loss of vacuum continues to occur after you have checked for an obstructions in the hose or wand. Also, install a new collection bag and pre-filter.

TROUBLESHOOTING

WARNING: TO REDUCE THE RISK OF ELECTRIC SHOCK-UNPLUG BEFORE TROUBLESHOOTING.

Symptom	Possible Causes	Corrective Action
Vacuum will not operate.	<ol style="list-style-type: none"> 1) No power supply. 2) Faulty power cord. 3) Tank full. 	<ol style="list-style-type: none"> 1) Check power supply – cord, breakers, fuses. 2) Unplug and check the power cord. If damaged, have it repaired by a professional. 3) Empty tank.
Dust comes out from motor cover.	<ol style="list-style-type: none"> 1) The cartridge filter is missing or damaged. 2) HEPA cartridge filter is not installed correctly. 	<ol style="list-style-type: none"> 1) Attach or replace cartridge filter. 2) Please make the screw down to fix the HEPA cartridge filter.
Reduced efficiency and motor/speed vibration.	<ol style="list-style-type: none"> 1) There is a blockage in the nozzle, hose, or the container inlet. The cartridge filter is clogged by fine dust. 	<ol style="list-style-type: none"> 1) Check nozzle, hose and container inlets for blockage. Take off the filter and clean it. Or install a new cartridge filter.

PARTS -EXPLODED VIEW

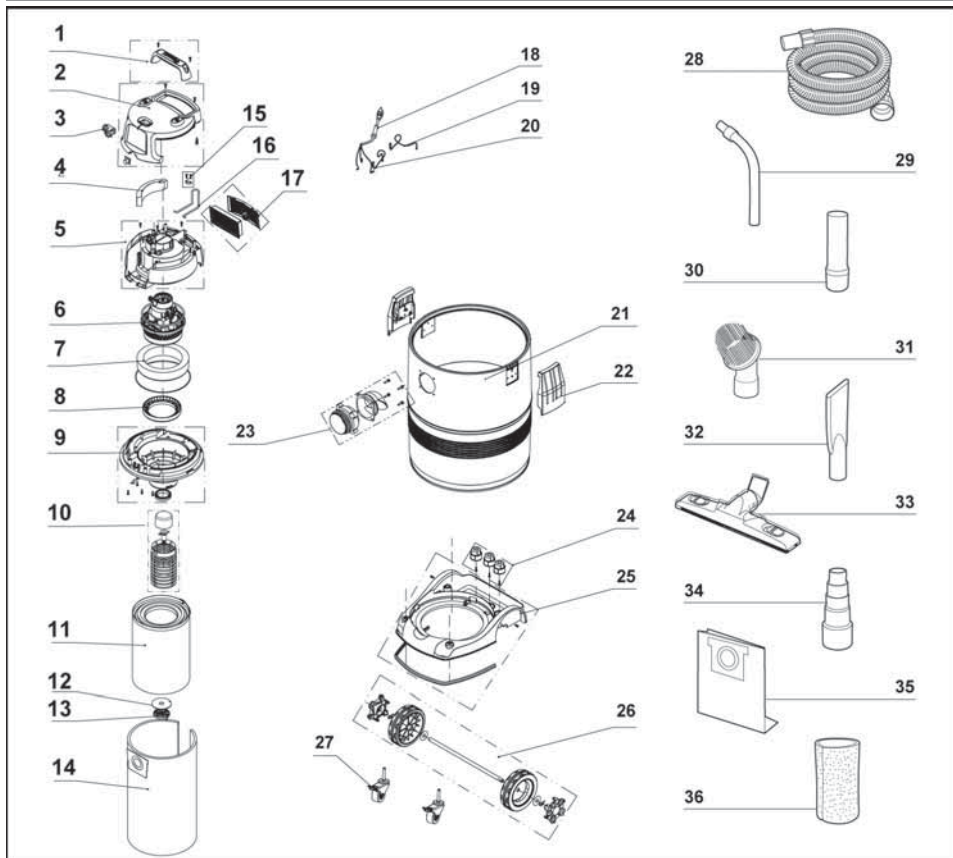

VK811PH Manual Parts List

Key Number	Drawing Number	Description	Quantity	Key Number	Drawing Number	Description	Quantity
1	VK01SR.A0.01	Handle Assembly	1	19	T0DXL1.64.U.L	Inner Cable	1
2	VK21SR.A0.04	Top Cover	1	20	T0DXL1.65.U.L	Inner Cable	1
3	W0DQ10.01.12	Switch	1	21	VK30PW.11.00	Tank	1
4	VK21SR.10.06	Filter Sponge	1	22	TVQTDK.05.00	Latch Assembly	2
5	VK30SR.A0.01	Mid Cover Assembly	1	23	TVQTXK.A0.03	Suction Assembly	1
6	TM9456.00.00	Motor Assembly	1	24	FV8203.A0.02	Tube Column Assembly	3
7	VI02SR.10.07	Foam	1	25	VK21SR.20.02	Base Assembly	1
8	VI02SR.10.04	Seal String	1	26	TVQTGL.A0.07	Wheel Assembly	1
9	VK30SR.10.02	Lid Assembly	1	27	TVQJL.25.00	Castor	2
10	VJ01PF.A0.02	Filter Basket Assembly	1	28	FV5804.01.00	Hose	1
11	VK30SR.A0.03	HEPA Cartridge Filter Assembly	1	29	FV5943.01.00	Extension Wands	1
12	VK30SR.10.09	flat rubber washer	1	30	FV5944.01.00	Accessory Adaptor	1
13	VK30SR.10.04	HEPA filter cartridge filter retainer	1	31	FV5773.02.00	Round Brush	1
14	FV9607.03.00	Qualified Dust Bag	1	32	FV5771.01.01	Crevice Nozzle	1
15	T0QTGX.A0.01	Cord Clamp Assembly	1	33	FV5723.00.00	Floor Squeegee	1
16	VK30SR.10.08	Cable Hook	1	34	FV5311.01.01	Adaptor For Power Tool	1
17	VK21SR.A0.03	HEPA Assembly	1	35	FV9660.02.00	Dust Collection Bag	1
18	VK30SR.A0.04	Cord Assembly	1	36	FV9506.01.00	Foam Sleeve	1

